

# iOX5

# SOLA

Gebrauchsanweisung

**Operating instructions**

Mode d'emploi

Istruzioni d'uso

Instrucciones de uso

Gebruiksaanwijzing

Руководство по применению

Instrukcja obsługi

Eksploatacijos instrukcija

Lietošanas instrukcija

DE

EN

FR

IT

ES

NL

RU

PL

LT

LV



## 10.1 Lieferumfang iOX5 Basis

- 1 Linien- Punktlaser **iOX5**
- 2 Batterieadapter **BA**
- 3 1,5V LR6 (AA) Batterien
- 4 Trockenbauadapter **TBA**
- 5 Gerätetasche klein



## 10.2. Lieferumfang iOX5 Profiset

- 1 Linien- Punktlaser **iOX5**
- 2 Batterieadapter **BA**
- 3 1,5V LR6 (AA) Batterien
- 4 Trockenbauadapter **TBA**
- 5 Gerätetasche klein
- 6 SOLA Li-Ion Akku **Li-Ion 5.2**
- 7 Li-Ion Ladestation **LST Li-Ion**
- 8 Li-Ion Ladegerät **LG Li-Ion**
- 9 Länderstecker EU/UK **LS-EU / LS-UK**
- 10 Kompaktstativ **FST**
- 11 Universalhalterung **UH**
- 12 Lasersichtbrille rot **LB red**
- 13 Magnetische Zielscheibe **ZS red**
- 14 Hängetasche groß

## 2.1.1 iOX5

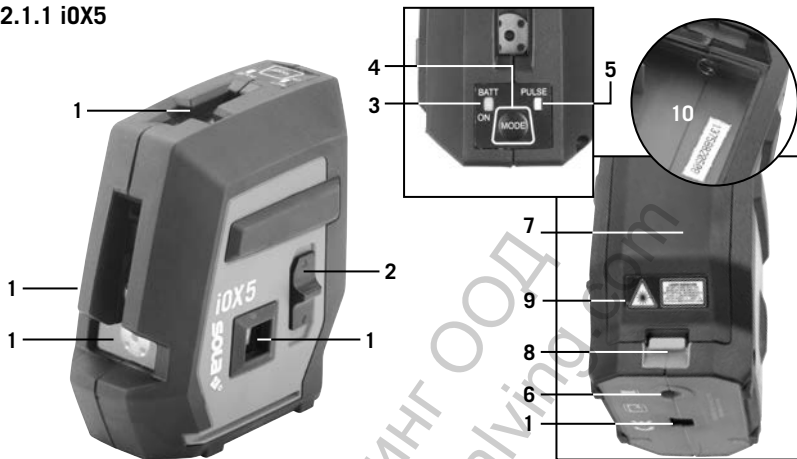

## 2.1.2 TBA

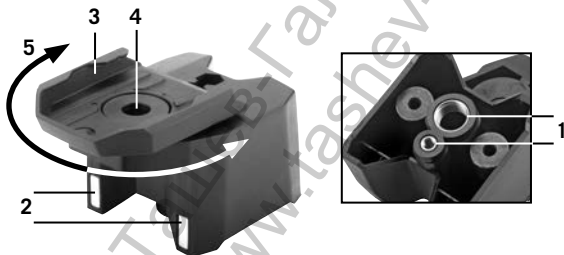

## 2.1.3 UH<sup>1,2</sup>

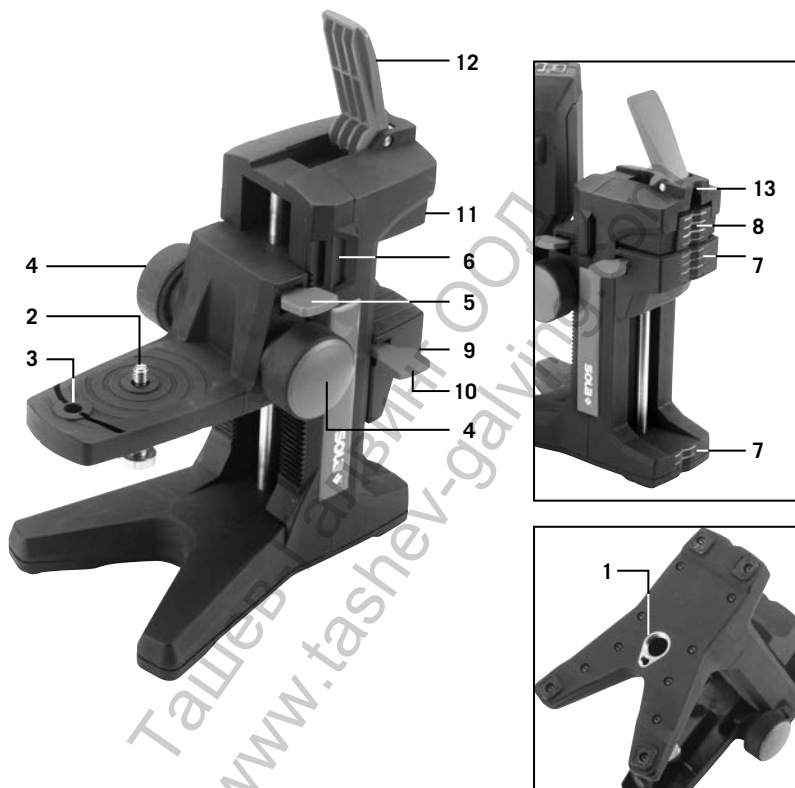

## 2.1.4 Li-ion Akku, Ladestation und Ladegerät<sup>1,2</sup>

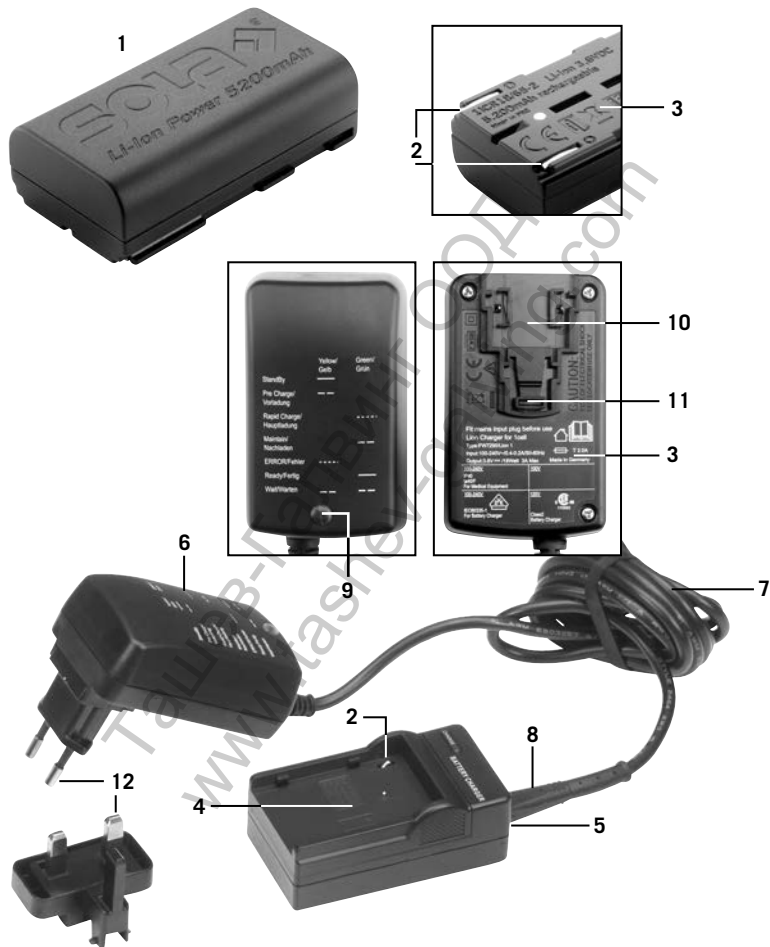

## 2.1.5 Empfänger iOX5-REC<sup>2</sup>

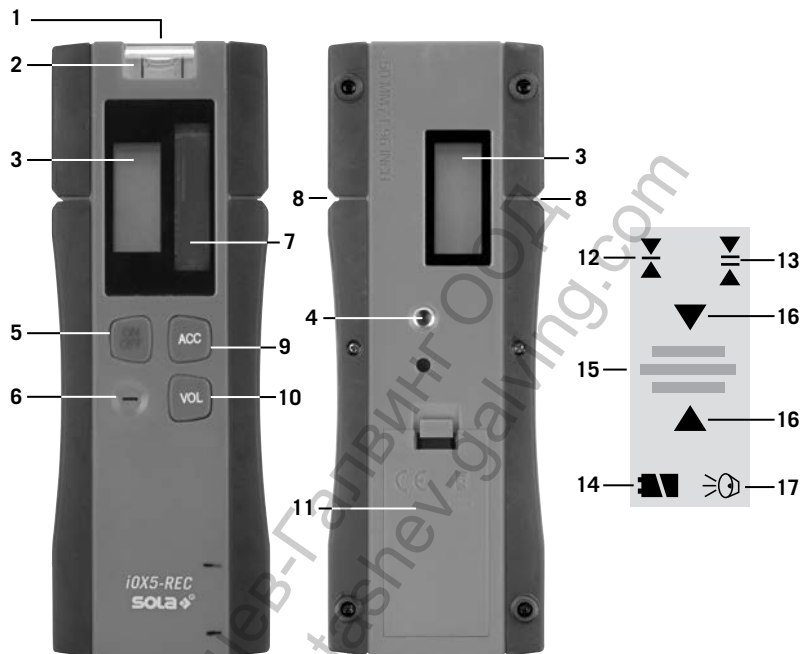

# Operating manual

## iOX5 Line/Point Laser

### About this manual

Congratulations on the purchase of your new iOX5! You have acquired a SOLA measurement instrument, which can make your work easier, faster and more precise.

To utilize the complete functionality range of this measurement instrument, and to ensure a safe operation, please observe the following instructions:

- Please read these operating manual before starting to use the device.
- Always keep the operating manual near the device.
- Only hand over the device to other persons together with the operating manual.
- Never render the attached warning signs unreadable.

### Contents

---

1. General information
2. Description
3. Technical data
4. Safety instructions
5. Laser classification
6. Startup
7. Operation
8. Checking the accuracy
9. Maintenance, storage and transportation
10. Scope of delivery and accessories
11. Troubleshooting
12. Disposal
13. Warranty
14. EC conformity declaration

# 1. General information

## 1.1 Signal words and their meaning

### DANGER

For an imminent danger that could lead to serious injury or death.

### WARNING

For a possibly dangerous situation that could lead to serious injury or death.

### CAUTION

For a possibly dangerous situation that could lead to slight injury or property damage.

### NOTE

For application notes and other useful information

## 1.2 Pictograms and other information

### 1.2.1 Warning signs



Warning of dangers in general

### 1.2.2 Symbols



Read instructions before use



Batteries and devices may not be disposed of with household waste



Do not throw batteries into the fire



Warning label on packages with Li-Ion batteries

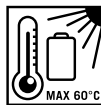

Warning signs on battery  
Do not heat the battery above 60° C.



Class 2 laser device



Do not look into the laser beam!



## 2. Description

---

### 2.1 Device components, display and operating elements

#### 2.1.1 iOX5

- 1 Laser beam output opening
- 2 On/off switch
- 3 Status/battery voltage display  
>ON - BATT<
- 4 Operating modes button >MODE<
- 5 Operating mode >PULSE<
- 6 Tripod adapter ¼"
- 7 Battery compartment cover
- 8 Battery compartment cover locking device
- 9 Laser warning label
- 10 Serial number

#### 2.1.2 Drywall adapter TBA

- 1 Tripod thread 5/8" and 1/4"
- 2 Nd magnet for drywall tracks
- 3 Holding fixture für iOX5
- 4 Opening for plumbing point
- 5 flexible 360° adjustment

#### 2.1.3 Universal holder UH1,2

- 1 Tripod thread 5/8" and 1/4"
- 2 Fixing screw 1/4" for iOX5
- 3 Opening for plumbing point
- 4 Height fine adjustment (upward adjustment)
- 5 Release button (downward adjustment)
- 6 Lug for tie strap (strap not included in the scope of delivery)
- 7 ND magnets for mounting on magnetic surfaces

- 8 V-groove for mounting on pipes
- 9 Clamping jaw bottom (movable)
- 10 Release button for the clamping jaw bottom
- 11 Clamping jaw top
- 12 Clamping lever
- 13 Nail hole

#### 2.1.4 SOLA Li-Ion battery, charging station and charger<sup>1,2</sup>

- 1 SOLA Li-Ion battery
- 2 Battery contacts
- 3 Technical Specifications / certification labels
- 4 Li-Ion battery charging station
- 5 Charging connector for the Li-Ion battery charging station
- 6 Li-Ion battery charger
- 7 Charging cable
- 8 Charger plug
- 9 Technical data
- 10 Connection socket for country-specific plugs
- 11 Release button for the country-specific plug
- 12 Länderstecker

### 2.1.5 Receiver iOX5-REC<sup>2</sup>

- |   |  |
|---|--|
| 1 Magnet  | 10 >VOL< button; signaling tone setting                              |
| 2 Spirit level  | 11 Battery compartment   |
| 3 Display (also visible from the rear)  | 12 Accuracy „Fine“   |
| 4 Thread for the receiver mounting fixture  | 13 Accuracy „Rough“  |
| 5 >ON/OFF< button   | 14 Battery status  |
| 6 Speaker   | 15 Reference laser beam centered                                     |
| 7 Detection window for the laser beam   | 16 Display position of the reference laser beam                      |
| 8 Marking point   | 17 Status signaling tone:  |
| 9 >ACC< button; setting of fine/rough accuracy; + lighting (press button for 2 seconds) | medium volume; speakers with three bars: very loud, no speaker: mute |

### 2.2 Intended use

The iOX5 is a Line/Point Laser which enables a single person to level and align plumbing points as well as 90 degree angles horizontally and vertically.

The device is designed to be preferably used indoors. For outdoor applications, it must be ensured that the ambient conditions similar to those indoors.

The visibility range of the laser lines depends on the ambient conditions. Under low light conditions or for long distances the receiver iOX5-REC can be used to locate the laser line position.

Follow the instructions contained in this manual. The device and accessory equipment may be a source of dangers if they are utilized improperly or inappropriately by persons who are not instructed as required.

- 1... In the iOX5 Set
- 2... accessories (optional)

### 3. Technical data

#### 3.1.1 Line/Point Laser iOX5

Application area \*

- Laser lines	r = 20 m*
- Laser points	r = 40 m*
- Receiver	r = 80 m*

Max. Measurement tolerance

- Laser lines and points	± 0.2 mm/m
- Laser cross top	± 0.3 mm/m

Protection class IP 54

Cross angle 90°

Levelling range (typical) ± 4°

Levelling time (typical) ≤ 5 sec.

Power supply 3 x 1.5V LR6 (AA) batteries / SOLA Li-Ion rechargeable battery

Operating time (at 20° C)

- LR6 (AA) batteries	11 h
- SOLA Li-Ion battery (5200 mAh)	23 h

permissible temperatures

Operating temperature -10° C to +50° C

Storage temperature -20° C to +60° C

Laser diodes Lines / points 635 / 650 nm < 1 mW

Laser class 2, DIN EN 60825-1 : 2007-10

Tripod adapter ¼"

Weight without battery 575 g

Dimension 115 x 65 x 125

\*... depending on the environmental conditions at the workplace.  
Changes (drawings, descriptions and technical data) are reserved.

#### 3.1.2 Receiver iOX5-REC

Application area: r = 2 - 80 m

Detection window size 40 mm

Max. Measurement tolerance

Fine ± 1.0 mm

Rough ± 3.0 mm

Protection class IP 52

Power supply	1 x 9V 6F22 (E-Block) battery
Operating time (at 20° C)	40 h
Operating temperature	-10° C to +50°C
Thread for mounting fixture	¼"
Weight without battery	210 g
Dimension	195 x 70 x 26 mm

### 3.1.3 SOLA Li-Ion battery 5.2

Type	Li-ion with protective electronics
Cells	2 x ICR 18650 parallel
Capacity	5200 mAh
Voltage	3.6 VDC
Performance	28 Wh
permissible temperatures	
Operating temperature	-10°C to +50°C
Storage temperature (ideal)	-20°C to +60°C (ideal +20°C to +25°C)
Charging temperature	0°C to +45°C (ideal +20°C to +25°C)
Humidity	65 ± 20 %
Charging time	3 - 5 h
Weight	100 g
Dimension	71 x 39 x 22 mm

### 3.1.4 SOLA charger LG Li-Ion

Nominal input voltage	100 - 240 VAC / 50-60 Hz
Nominal input current	0.4A @ 100VAC - 0.2A @ 240VAC under maximum load
Nominal input power	21 Wrms under max load
Output voltage	3.6 VDC
Charging current	3000 mA
Ambient temperature	-10°C - +50°C
Protection class	IP41
Power consumption during standby	≤ 0.3 W @ 100VAC / ≤ 0.5W @ 240VAC

## 4. Safety instructions

---

### 4.1 AREA OF RESPONSIBILITY

---

#### 4.1.1 Manufacturer

SOLA is responsible for the safe delivery condition of the product, including the operating manual and the original accessories.

#### 4.1.2 Operator

The operator is responsible for using the product as intended, the deployment of his personnel, their training and the operational safety of the product.

- > He understands the safety information which is stated on the product and the instructions which are contained in the operating manual.
- > He shall comply with local regulations relating to safety and accident prevention regulations as well as worker protection laws and regulations.
- > He shall immediately notify SOLA if safety-related issues should develop on the product or during its utilization.
- > He shall ensure that the product is not utilized any further if defects become evident, and he will have the product repaired professionally.

#### 4.2 Improper Use

---

- > Use of the device and the accessories without instruction.
- > Use of third-party accessories or additional equipment.
- > Use outside of the intended limits (see Chapter 3 / Technical Specifications).
- > Use under extreme temperature fluctuations without an adequate acclimatization.
- > Disabling of safety devices and removal of hazard notices and labels.
- > Unauthorized opening of the device.
- > Performance of modifications or alterations the device or the accessories.
- > Deliberate blinding of third parties.
- > Inadequate safeguarding at the installation site.

#### 4.3 Utilization limitations

---

The iOX5 is suitable for a continuous use in an atmosphere which can be inhabited by humans.

- > Do not operate the product in explosion-prone or corrosive environments.
- > Inform the local safety authorities and safety experts before working in hazardous environments, in close proximity to electrical installations or similar surroundings.

## 4.4 USAGE HAZARDS

### 4.4.1 General



#### WARNING

Missing or incomplete instructions may result in improper or incorrect use. This can cause accidents with serious damages to persons, property, assets and the environment.

- > Follow the manufacturer's and operator's safety instructions.
- > Protect equipment and accessories from access through children.



#### WARNING

Blinding by laser radiation can indirectly lead to serious accidents, especially for people who are driving a vehicle or operating machinery.

- > Do not look into the laser beam.
- > Do not set up the laser beam and the laser plane at eye level or aim at people.



#### CAUTION

A fall, longer storage, transportation or other mechanical effects can lead to erroneous measurement results.

- > Check the unit for damage before use.
- > Do not use damaged equipment. Repairs have to be exclusively performed by SOLA
- > Before use, check the accuracy of the device (see Chapter 8 / Checking the accuracy).

### 4.4.2 Charger / batteries / rechargeable batteries



#### DANGER

There is a risk of mortal danger from electric shock.

- > Never open the SOLA Li-Ion battery charger or charging station.
- > Only use the SOLA Li-Ion battery charger and charging station in dry places and do not bring them into contact with liquids.





#### DANGER

Strong mechanical influences, can lead to a leakage, fire or explosion of the batteries or trigger the release of toxic substances.

- > Batteries and rechargeable batteries may not be opened or exposed to mechanical loads.
- > Damaged batteries, chargers and charging stations may not be used. Repairs have to be exclusively performed by SOLA

-  **WARNING** High ambient temperatures and immersion into liquids can cause a leakage, fire or explosion of the batteries or trigger the release of toxic substances.
- > Protect batteries and rechargeable batteries from mechanical influences during transport.
  - > Never store the Li-Ion battery in the sun, on radiators or behind glass windows.
  - > Do not overheat batteries and rechargeable batteries or expose them to fire.
  - > Avoid the ingress of moisture into batteries and rechargeable batteries.
  - > Do not use damaged batteries or rechargeable batteries. Perform a proper disposal (see Chapter 12 / Disposal).

-  **WARNING** A short-circuiting or unintended use can cause batteries to overheat and create an injury or fire hazard.
- > Do not transport or store batteries in the pockets of garments.
  - > Do not bring the battery contacts in contact with jewelry, keys, or other electrically conductive objects.
  - > Do not charge the batteries.
  - > Do not discharge the batteries through short-circuiting.
  - > Do not solder the batteries within the device.
  - > Do not mix old and new batteries, and do not mix batteries from different manufacturers or with a differing type designation.

-  **WARNING** Using charging devices from other manufacturer's can damage the Li-Ion batteries. This can lead to a fire and explosion hazard.
- > Only use original SOLA accessories.

**WARNING**

If disposed of improperly third parties can possibly be seriously injured and the environment polluted.

The burning of plastic components generates toxic fumes which may impair health of people.

Batteries / rechargeable batteries may explode if they are damaged or heated excessively, and thereby cause poisoning, burning, corrosion or environmental contamination.

If disposed of negligently unauthorized persons are able to use the product improperly.

- > The product may not be disposed of together with household waste. Perform a proper disposal of the device and the accessories (see Chapter 12 / Disposal).
- > Protect the product at all times from access through unauthorized persons, and especially children.

**4.5 ELECTROMAGNETIC COMPATIBILITY (EMC)**

---

The electromagnetic compatibility is the ability of the product to function in an environment with electromagnetic radiation and electrostatic discharges were are present, without causing an electromagnetic interference for other devices.

**4.5.1 Interference for other devices through iQX5**

Although the product meets the strict requirements of the relevant directives and standards, SOLA can not completely exclude the possibility of interference with other devices (for example, when using the product in combination with third-party devices, such as field computers, personal computers, wireless devices, mobile phones, certain cables or external batteries).

- > When using computers and radio equipment make sure to observe to the vendor-specific information about electromagnetic compatibility.
- > Only use original SOLA equipment and accessories.

**4.5.2 Interference of the iQX5 through other devices**

Although the product meets the strict requirements of the relevant directives and standards, SOLA can not entirely exclude the possibility that an intense electromagnetic radiation in the immediate vicinity of radio transmitters, two-way radios, diesel generators, etc. can distort the measurement results.

- > When performing measurements under these conditions check the plausibility of the results.



## 5. LASER SAFETY / CLASSIFICATION

The four iOX5 emits four visible laser lines and three laser points.

The product corresponds to the Laser Class 2 according to DIN EN 60825-1: 2007-10

Laser Class 2:

When using Class 2 laser devices the eye is protected by the eyelid closure reflex or evasive reactions in case of a random and short-term exposure.



### WARNING

Looking directly into the beam with optical aids (e.g. binoculars, telescopes) can be dangerous.

### CAUTION

Looking into the laser beam may be hazardous to the eye.

- > Do not look into the laser beam.
- > Do not aim the laser beam at other people.

Labeling on the device:

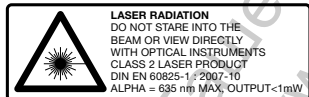

For the position of the type plate refer to the inside of the cover page.

- > Do not remove the type plate!

## 6. Startup

### 6.1 iOX5

#### 6.1.1 Operation with alkaline batteries

1. Insert batteries with the correct polarity into the battery adapter supplied by SOLA.
2. Open the battery compartment cover on the rear side of the device.
3. Insert the SOLA battery adapter in the correct position.
4. Close the battery compartment (audible click of the cover).

Only use alkaline-manganese batteries type 1.5V LR06 (AA)!

If the device is not used for a longer period of time, remove the batteries.



NOTE: The intensity of the laser lines can vary depending on the battery quality. The best visibility can be achieved with the SOLA Li-Ion battery.

#### 6.1.2 Operation with the SOLA Li-Ion battery<sup>1,2</sup>

1. Fully charge the battery with SOLA Li-Ion charger (see Chapter 7.2).
2. Open the battery compartment cover on the rear side of the device.
3. Insert the SOLA Li-Ion battery in the correct position.
4. Close the battery compartment (audible click of the cover).

If the device is not used for a longer period of time, remove the battery and store it in a dry location (see Chapter 9 / Maintenance, storage and transport).

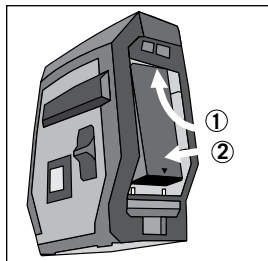
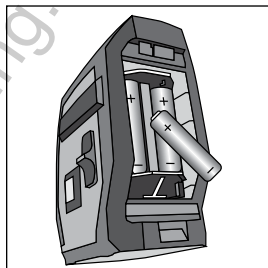
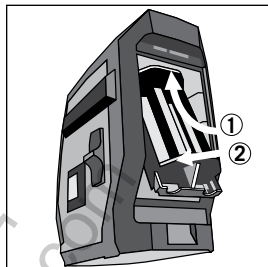

## 6.2 Receiver iOX5-REC<sup>2</sup>

1. Open the battery compartment cover on the rear side of the device.
2. Insert the battery as shown on the inside of the device.
3. Close the battery compartment (audible click of the cover).

Only use alkaline-manganese batteries type 9V 6F22 (E-Block)!

If the device is not used for a longer period of time, remove the battery.

- 1... In the iOX5 Pro-Set
- 2... accessories (optional)

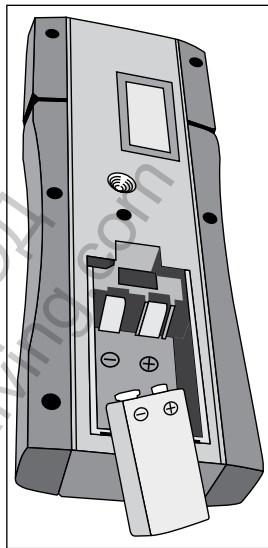

## 7. Operation

---

### 7.1 iOX5

---

#### 7.1.1 On/off switching

**On:**

- > Move the sliding switch downward (the device will emit all lines and points from the orifices).

The instrument will level itself automatically within the specified inclination range (see Chapter 3 / Technical data).

**Off:**

- > Move the sliding switch upwards, the pendulum unit will be locked.



**NOTE**

Magnets can affect the measurement instrument and lead to false results.

If the vertical laser line is not projected vertically to the wall or to the detection surface, uneven surfaces can lead to erroneous measurement results.

- > Make sure that the vertical laser line is projected vertically to the wall or to the detection surface.

Severe temperature fluctuations can lead to erroneous measurement results.

- > Before startup the device let it acclimate to the environmental conditions.

The >ON - BATT< indicator will blink when the battery capacity falls below 10%.

- > Charge the battery in time or provide an additional SOLA Li-Ion replacement battery.

#### 7.1.2 PULSE mode

The handheld receiver (iOX5-REC) can be used, to be able to detect the laser lines even greater distances or under unfavorable environmental conditions. For this, the iOX5 must be used in the pulse operating mode.

**On:**

- > Switch-on the iOX5.
- > Press the >MODE< button -> display >PULSE< will be lit.

**Off:**

- > Press the MODE button -> display >PULSE< will be off.

 **NOTE**  
Using the >PULSE< mode can save energy and extend battery life by up to 60 %, if a particularly good visibility of the laser lines is not required.

### 7.1.3 Creating inclinations beyond the range of the automatic leveling

#### On:

- > Switch off the IOX5 (move the sliding switch to the OFF position)
  - > Press and hold the >MODE< button for 4 sec. -> display >PULSE< will be lit.
- To indicate that the self-leveling is switched off, the lines will blink every 4 seconds.

#### Off:

- > Press and hold the >MODE< button for 4 sec. -> display >PULSE< will be off.

 **NOTE**  
If the laser line is not projected vertically to the surface, uneven areas can lead to erroneous measurement results.

- > Make sure that the laser line is projected vertically to the wall or to the detection surface.

## 7.2 SOLA Li-Ion battery, charging station & charger

---

Before the initial startup, the SOLA Li-Ion battery must be fully charged.

- > Plug the charger plug into the charging port of the Li-Ion Charger
- > Connect the SOLA Li-Ion battery charger to a socket-outlet
- > Insert the SOLA Li-Ion battery in the correct position.
- > Depending on the charge state and the environmental conditions the charging time will be between 3 and 5 hours
- > After 10 charging cycles the battery will reach its full capacity.
- > Ideally, the battery should always be fully charged. In urgent cases, the battery can be removed from the charging station before the charging process has been fully completed. This does not adversely affect the service life of the battery (no memory effect).

**Operation indicator:**

Colour	Display	Mode	Description
yellow green		Standby	No battery in the charger
yellow green		Wait cycle	Battery temperature beyond the valid range
yellow green		Pre-charge	Protective charging for deeply discharged batteries
yellow green		Main charge	Rapid charging phase with max. power up to 80%
yellow green		Recharging	Recharging between 80 - 100%
yellow green		Completed	Charging process completed Battery is 100% charged
yellow green		Error	Battery too hot / too cold, let it acclimatize and reinsert

Capacity	Display	Mode
100 %		Charging process completed
80 %		Recharging
		Main charge
		Pre-charge

## 7.3 Receiver iOX5-REC

### 7.3.1 On/off switching

**On:** Press the >ON/OFF< button.

**Off:** Press the >ON / OFF< button again.

- > Turn the operating area of the receiver towards the laser device and make sure that the reception window is perpendicular to the line plane.
- > Move the receiver up and down until a signaling tone can be heard or direction arrows become visible on the display.

If the marking location of the receiver is located above the laser beam a slow pulsed signaling tone will sound, and the screen will display a downward pointing arrow icon.

- > Move the receiver in the downward direction as indicated by the arrow.

If the marking location of the receiver is located below the laser beam a fast pulsed signaling tone will sound, and the screen will display an upward pointing arrow icon.

- > Move the receiver in the upward direction as indicated by the arrow.

If there is a constant signaling tone or if only the middle bar is still visible, the marking location is exactly aligned with the laser beam.

- > Now you can use a pen to mark the height of the laser beam at the marking locations. Using the spirit level you are now able to check that you holding the receiver leveled and that the markings are therefore on the same level.



#### NOTE

- Both the horizontal and the vertical lines are detectable.
- > When measuring, ensure that the desired laser line is detected.

If the ACC button is pressed for more than 2 seconds, the LCD screen will be illuminated. The receiver has an automatic shutoff function. If a laser beam is not received or a button pressed for more than 10 min. the receiver will automatically switch-off.

## 7.4 Applications

### 7.4.1 Setting up a drywall.

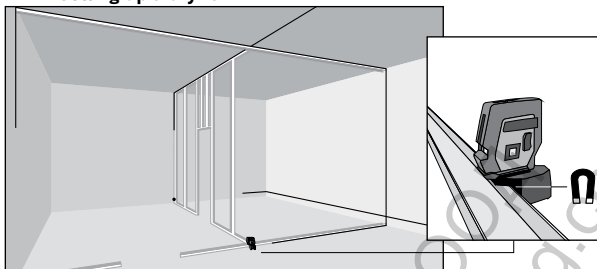

### 7.4.2 Ceiling suspension

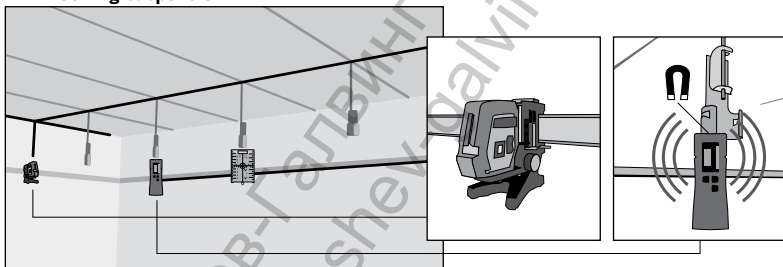

### 7.4.3 Inclination

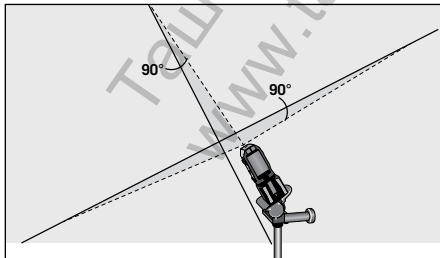



## 8. Checking the accuracy

Check accuracy of the SOLA iOX5 before each measurement.

> Before starting the check let the device acclimate to the environmental conditions.

### 8.1 Checking the accuracy of the vertical plumbing

Mount the laser onto a tripod in a 5-10 m high room (e.g. staircase).

> Switch-on the iOX5.

> Mark the vanishing point ① on the ceiling and the plumbing point ① on the floor (with a target).

> Rotate the iOX5 by 180° and align it directly to the marking ① on the ground using the plumbing point.

> Mark the vanishing point ② on the ceiling.

> Measure the difference ④ between ① and ②.

The accuracy of the plumbing can be calculated as follows:  $G = \frac{10 \times d}{H}$

G ... the plumbing accuracy (mm)

d ... difference between the ceiling vanishing points (mm)

H ... room height in (m)

If G is greater than 6 mm, the device must be readjusted. In this case, consult your dealer.

### 8.2 Checking the accuracy of the vertical line

> Attach a plumb line as close as possible to a 3m high wall.

> Mount the iOX5 onto a tripod at a height of approx. 1.2 m.

> Position the device approx. 3 m in front of the plumb line.

> Switch on the iOX5 and project the vertical laser line onto the plumb line.

If the deviation is greater than 4 mm, the device must be readjusted. In this case, consult your dealer.

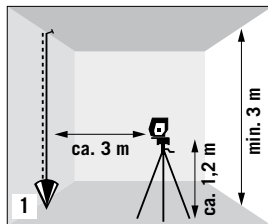
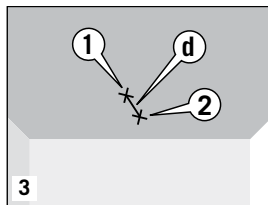
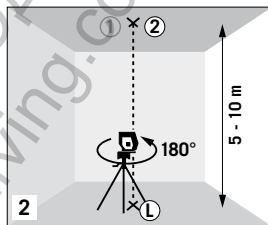
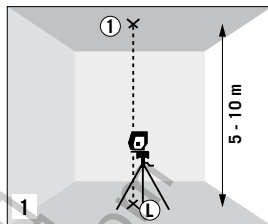

### 8.3 Checking the leveling accuracy of the horizontal line

- Select two horizontal, flat walls (A & B), which are approx. 10 meters apart.
  - > Mount the iOX5 onto a tripod and position it at a distance of approx. 20 cm from wall A.
  - > Mark the intersecting point ① of the vertical and horizontal line on wall A.
- Rotate the iOX5 by 180° and mark point ② on wall B.
  - > Position the laser at the same height approx. 20 cm away from wall B and mark point ③ on wall B.
- Rotate the iOX5 by 180° and mark point ④ on wall A.
  - > Measure the vertical distance  $d_1$  of the marked points ① - ④ and the vertical spacing  $d_2$  of the points ② - ③.
  - > Mark the center point of  $d_1$  and  $d_2$ .
  - > If the reference points ① und ③ are on different sides of the center point,  $d_2$  must be **subtracted** from  $d_1$ .
  - > If the reference points ① und ③ are on the same side as the center point,  $d_2$  must be **added** to  $d_1$ .
  - > Divide the results with double the value of the room length. The result with twice the value of the room length.

If the result is greater than 4 mm, the device must be readjusted. For this, please consult your dealer.

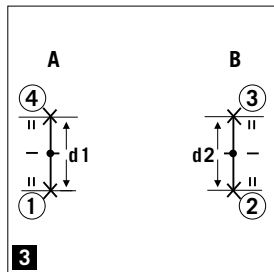
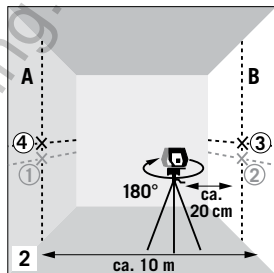
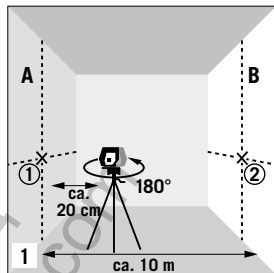

### 8.4 Checking the leveling accuracy of the lateral axis

- > Procedure and calculation as in 8.3 using the lateral plumbing beams

### 8.5 Checking the perpendicularity of the lateral axis

1. Select a room with a square floorplan, in which the walls are approx. 10 meters apart.
  - > Position the device in the middle of the room on a tripod and align the vertical laser line perpendicular to one of the walls.
  - > Mark the center of the lower plumb beam (L) on the floor (with a target).
  - > Mark the intersecting point (1) of the vertical and horizontal laser line (with a target).
  - > Mark the center of the right lateral plumb beam (2) (with a target).

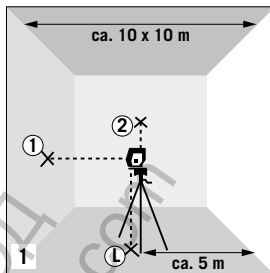

2. Rotate the device 90° clockwise.
  - > The lower plumb beam must remain on the marking (L) and the left lateral plumb beam must be exactly aligned to the mark (1).
  - > Mark the intersecting point (3) of the vertical and horizontal laser line (with a target).
  - > Mark the center of the right lateral plumb beam (4) (with a target).

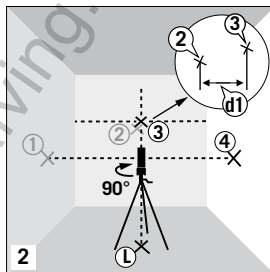

**NOTE:** the horizontal distance (d1) between the marked points (2) and (3) may only be a max. of 3 mm at a measuring distance of 5 m.

3. Rotate the device 180° clockwise.
  - > The lower plumb beam must remain on the marking (L) and the right lateral plumb beam must be exactly aligned to the mark (1).
  - > Mark the center of the left lateral plumb beam (5) (with a target).

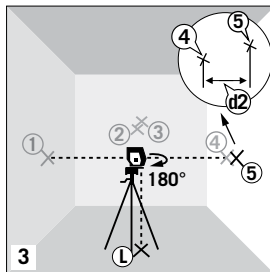

**NOTE:** the horizontal distance (d2) between the marked points (4) and (5) may only be a max. of 3 mm at a measuring distance of 5 m.

**NOTE:** If the marked point ③ is to the right of point ②, the **sum** of the horizontal distances  $d_1$  and  $d_2$  may only be a max. of 3 mm at a measuring distance of 5 m.

**NOTE:** If the marked point ③ is to the left of point ②, the **difference** of the horizontal distances  $d_1$  and  $d_2$  may only be a max. of 3 mm at a measuring distance of 5 m.

## 9. Maintenance, storage and transportation

---

### 9.1 Cleaning

---

- > Wipe off the dirt with a soft damp cloth.
- > Check the outlet openings of the laser regularly, and thoroughly clean them if necessary. Do not touch the glass with your fingers.
- > Do not use aggressive cleaning agents or solvents.
- > Do not immerse the device into water!
- > Clean and dry wet equipment, accessories and transport containers prior to packaging them. Only pack equipment again when it is completely dry.
- > Keep plug connections clean and protected from moisture.

### 9.2 Storage

---

#### 9.2.1 General

- > The equipment may only be stored within the specified temperature limits (see Chapter 3 / Technical data).
- > After a prolonged storage check the accuracy of the measuring device before using it.

#### 9.2.2 Batteries / rechargeable batteries

- > For storage, remove the batteries from the device or from the charging station.
- > The storage should preferably be performed in a dry environment at room temperature (see Chapter 3 / Technical data).
- > Protect from moisture and humidity. Dry wet or damp batteries before the storage, or respectively before usage.
- > Prior to a prolonged storage charge the battery to 80% capacity (see Chapter 7 / operation). Repeat the procedure every 6 months.
- > After storage, fully charge the battery before use.
- > Check the battery for damage before use. Do not use damaged batteries!

## 9.3 Transport

### 9.3.1 General

The device may be damaged through strong vibrations or by falling.

Never transport the product loosely. Always use the original packaging or an equivalent transport container.

- > Switch off the measuring device before transporting it. During the shutdown the pendulum unit is locked in position and protected against damage.
- > Check the unit for damages before use.
- > Regularly check the accuracy of the device (see Chapter 8 / Checking the accuracy).

### 9.3.2 Batteries / rechargeable batteries

When transporting or shipping batteries, the operator is responsible for complying with the applicable national and international laws and regulations.

- > Before shipping, remove the batteries from the device.

Li-ion batteries fall under the jurisdiction governing hazardous goods, but they may be transported on the road by their operator without further stipulations.

When shipping through third parties (e.g. forwarding agent or air freight) the special requirements regarding the packaging and labeling must be observed.

- > Remove the battery from the device and ship it in its storage condition (80% capacity).
- > Cover exposed contacts with tape.
- > Package the battery in such a manner that it can not move around in the packaging, and that it can not be damaged by external influences.
- > Further national and international regulations and any additional requirements as well as the stipulations of the respective transport company must be observed.

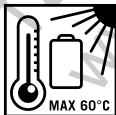

## 10. Scope of delivery and accessories

---

### 10.1 Scope of delivery iOX5 Basic

---

- 1 Line/Point Laser **iOX5**
- 1 Battery adapter **BA**
- 3 1.5V LR6 (AA) batteries
- 1 Drywall adapter **TBA**
- 1 Operating manual
- 1 Diagnostic form for complaints
- 1 Device pouch small

### 10.2 Scope of delivery iOX5 ProSet

---

- 1 Line/Point Laser **iOX5**
- 1 Battery adapter **BA**
- 3 1.5V LR6 (AA) batteries
- 1 Drywall adapter **TBA**
- 1 Operating manual
- 1 Diagnostic form for complaints
- 1 Device pouch small
- 1 SOLA Li-Ion batteries **Li-Ion 5.2**
- 1 Li-Ion charging station **LST Li-Ion**
- 1 Li-Ion battery charger **LG Li-Ion**
- 1 Country-specific plug EU / UK  
**LS-EU / LS-UK**
- 1 Compact tripod **FST**
- 1 Thread adapter for **FST**
- 1 Universal holder **UH**
- 1 Laser goggles red **LB red**
- 1 Magnetic target **ZS red**
- 1 Hanging bag large

### 10.3 ACCESSORIES (optional)

---

- Receiver with holding fixture and 9V 6F22 (E-Block) battery **iOX5-REC**
- Battery adapter **BA**
- SOLA Li-Ion Battery Set
- 1 SOLA Li-Ion battery **Li-Ion 5.2**
- Li-Ion charging station **LST Li-Ion**
- Li-Ion battery charger **LG Li-Ion**
- Country-specific plug EU **LS-EU**
- Country-specific plug UK **LS-UK**
- Car adapter **CC**
- Compact tripod **FST**
- Universal holder **UH**
- Laser goggles red **LB red**
- Magnetic target **ZS red**

Further information regarding the accessories can be obtained at [www.sola.at](http://www.sola.at)

## 11. Troubleshooting

<b>Error</b>	<b>Possible cause</b>	<b>Troubleshooting</b>
Device is switched on, display >ON - BATT< does not light up and there is no visible laser beam.	<ul style="list-style-type: none"> <li>&gt; Battery empty</li> <li>&gt; Rechargeable battery empty</li> <li>&gt; Battery / rechargeable battery inserted incorrectly</li> <li>&gt; Device or switch defective</li> </ul>	<ul style="list-style-type: none"> <li>&gt; Replace the battery</li> <li>&gt; Recharge or replace battery</li> <li>&gt; Insert the batteries / rechargeable batteries correctly</li> <li>&gt; Contact the dealer and have the device repaired.</li> </ul>
Device turns off again immediately after startup.	<ul style="list-style-type: none"> <li>&gt; Battery empty</li> <li>&gt; Rechargeable battery empty</li> </ul>	<ul style="list-style-type: none"> <li>&gt; Replace the battery</li> <li>&gt; Recharge or replace battery</li> </ul>
Device is switched on, display >ON - BATT< lights up, but there is no visible laser beam.	<ul style="list-style-type: none"> <li>&gt; Ambient temperature too high / low</li> <li>&gt; Laser diode or laser control defective</li> </ul>	<ul style="list-style-type: none"> <li>&gt; Allow for an acclimatization of the device</li> <li>&gt; Contact the dealer and have the device repaired.</li> </ul>
Device is switched on, display >ON - BATT< lights up, but some laser beams are not visible.	<ul style="list-style-type: none"> <li>&gt; Laser diode or laser control defective</li> </ul>	<ul style="list-style-type: none"> <li>&gt; Contact the dealer and have the device repaired.</li> </ul>
Laser lines blink in one second intervals	<ul style="list-style-type: none"> <li>&gt; Device is beyond the self-leveling range</li> </ul>	<ul style="list-style-type: none"> <li>&gt; Align the device horizontally</li> </ul>
The >ON - BATT< indicator is blinking	<ul style="list-style-type: none"> <li>&gt; Battery capacity is less than 10%</li> </ul>	<ul style="list-style-type: none"> <li>&gt; Recharge the battery in time</li> </ul>
Laser lines blink every 4 seconds.	<ul style="list-style-type: none"> <li>&gt; Device is in the manual inclination mode</li> </ul>	<ul style="list-style-type: none"> <li>&gt; Press and hold the &gt;MODE&lt; button for 4s or switch on the laser device</li> </ul>

## 12. Disposal

If disposed of improperly third parties can possibly be seriously injured and the environment polluted.

The burning of plastic components generates toxic fumes which may impair health of people.

Batteries / rechargeable batteries may explode if they are damaged or heated excessively, and thereby cause poisoning, burning, corrosion or environmental contamination. If disposed of negligently unauthorized persons are able to use the product improperly.

Measuring tools, accessories and packaging must be recycled in an environmentally-friendly manner.



The product as well as the accessories - especially the batteries and rechargeable batteries - may not be disposed of with household waste.

- > Perform a proper disposal of the device and the accessories.
- > Only dispose of batteries in a discharged state.
- > Observe the country-specific disposal requirements.

Your SOLA dealership will take back batteries as well as old equipment, and will ensure a proper disposal.

### Only for EU countries



Electric tools may not be disposed of with household waste!

According to the European Directive 2002/96/EC on Waste Electrical and Electronic Equipment and its implementation in national law, no longer usable electrical and electronic equipment must be collected separately and recycled in an environmentally friendly manner.



## 13. Manufacturer's Guarantee

---

„The manufacturer warrants to the original purchaser who is stated on the guarantee card, the freedom from defects for the device for a period of two years, with the exception of batteries, as of the point in time the device is handed over. The guarantee is limited to repairs and / or replacements at manufacturer's discretion. Defects which are caused through improper handling by the purchaser or third parties, natural wear and optical flaws that do not affect the usability of the equipment, are not covered by this guarantee. Claims under this guarantee can only be invoked if the device is submitted along with the guarantee card, completely filled out by the dealer, dated and provided with the company stamp. If the guarantee claim is justified, the manufacturer shall bear the transport costs. The duration of the guarantee will not be extended through repair or spare parts work which is carried out within the scope of the guarantee.

Further claims are excluded, unless there are provided by the respective national legislation. In particular the manufacturer shall not be liable for any direct, indirect, incidental or consequential damages, losses or expenses in connection with the use or because of the inability to use the tool for any purpose whatsoever. Implied warranties for the usage or suitability for a particular purpose are expressly excluded.“

## 14. EC conformity declaration



**Konformitätserklärung  
Declaration of Conformity  
Declaration de Conformité**



Wir / We / Nous **SOLA Messwerkzeuge GmbH, A-6840 Götzis, Austria**

erklären in alleiniger Verantwortung, dass das Produkt(e)  
declare under our sole responsibility that the Product(s)  
déclarons sous notre seule responsabilité que le produit(s)

### **iOX5, Line Receiver iOX5-REC, Sola Akku Li-Ion 5.2, Li-Ion Ladegerät LG Li-Ion**

Auf das sich diese Erklärung bezieht, mit den folgenden Normen übereinstimmt.  
To which this declarations relates is in conformity with the following standards.  
Auquel se réfère cette déclaration est conforme aux normes.

<b>EN 55014-1:2007</b>	<b>EN 60601-1-2:2006</b>	<b>EN 60601-1:2006</b>
<b>EN 55014-2:2009</b>	<b>EN 61000-3-3:2008</b>	<b>EN 61326-1:2006</b>
<b>EN 55022:2008</b>	<b>EN 61000-6-2:2006</b>	<b>EN 62133:2003</b>
<b>EN 60335-1:2010</b>	<b>EN 61000-6-3:2006</b>	<b>UN38.3</b>
<b>EN 60335-2-29:2005</b>	<b>EN 61010-1:2011</b>	
<b>EN 61000-3-2:2006 + A1:2009 + A2:2009</b>		

Gemäss den Bestimmungen der Richtlinie(n)  
Following the provisions of Directive(s)  
Conformément aux dispositions de Directive(s)

**Electromagnetic compatibility 2004/108/EC  
Low Voltage Directive 2006/95/EC**

SOLA-Messwerkzeuge/GmbH

Mag. Wolfgang Scheyer CEO

SOLA-Messwerkzeuge GmbH, Unteres Tobel 25, A-6840 Götzis, Austria  
Phone +43(0)5523 53380, sola@sola.at, www.sola.at

# Herstellergarantie iOX5

Limited warranty iOX5

Seriennummer / Serial no.

Firma / Company / Name

Adresse / address

Telefon / Telephone



**SOLA-Messwerkzeuge GmbH**

Unteres Tobel 25  
A-6840 Götzis  
Austria

**SOLA** 

Kaufdatum / Stempel / Unterschrift des Händler    Date of purchase / Stamp / Signature (dealer)

